

APPLICABLE STANDARD					
RATING	OPERATING TEMPERATURE RANGE	-40°C TO 85°C	STORAGE TEMPERATURE RANGE	-40°C TO 60°C	
	VOLTAGE	125 V AC	OPERATING HUMIDITY RANGE	5 %RH TO 95 %RH	
	CURRENT	No.2 TO No.17 : 0.5 A No.1 AND No. 18 : 1.5 A			
SPECIFICATIONS					
ITEM	TEST METHOD	REQUIREMENTS	QT	AT	
CONSTRUCTION					
GENERAL EXAMINATION	VISUALLY AND BY MEASURING INSTRUMENT.	ACCORDING TO DRAWING.	X	X	
MARKING	CONFIRMED VISUALLY.		X	X	
ELECTRIC CHARACTERISTICS					
CONTACT RESISTANCE	100 mA (DC OR 1000 Hz).	70 mΩ MAX.	X	—	
INSULATION RESISTANCE	250 V DC.	1000 MΩ MIN.	X	—	
VOLTAGE PROOF	350 V AC FOR 1 min.	NO FLASHOVER OR BREAKDOWN.	X	X	
MECHANICAL CHARACTERISTICS					
INSERTION AND WITHDRAWAL FORCES	MEASURED BY APPLICABLE CONNECTOR.	25 N MAX.	X	—	
MECHANICAL OPERATION	20,000 TIMES INSERTIONS AND EXTRACTIONS.	1) AMOUNT OF CHANGE OF CONTACT RESISTANCE : 20mΩ MAX 2) NO DAMAGE, CRACK AND LOOSENESS OF PARTS.	X	—	
VIBRATION	FREQUENCY 10 TO 55 Hz SINGLE AMPLITUDE 0.75 mm, AT 2 h, FOR 3 DIRECTIONS.	1) NO ELECTRICAL DISCONTINUITY OF 10μs. 2) AMOUNT OF CHANGE OF CONTACT RESISTANCE : 20mΩ MAX	X	—	
SHOCK	490 m/s ² DIRECTIONS OF PULSE 11 ms AT 3 TIMES FOR 3 DIRECTIONS.	3) NO DAMAGE, CRACK AND LOOSENESS OF PARTS.	X	—	
ENVIRONMENTAL CHARACTERISTICS					
DAMP HEAT (STEADY STATE)	EXPOSED AT 60°C , 90~95%, 96h	1) AMOUNT OF CHANGE OF CONTACT RESISTANCE : 20mΩ MAX	X	—	
RAPID CHANGE OF TEMPERATURE	TEMPERATURE -55 → 5-35 → +85 → 5-35 °C TIME 30 → 2~3 → 30 → 2~3 min. UNDER 5 CYCLES.	2) INSULATION RESISTANCE: 1000 MΩ MIN. (AT DRY) 3) NO DAMAGE, CRACK AND LOOSENESS OF PARTS.			
CORROSION SALT MIST	EXPOSED IN 5 % SALT WATER SPRAY FOR 48 h.	NO HEAVY CORROSION.	X	—	
MIXED GAS CORROSION	EXPOSED IN SO ₂ 10 ppm , H ₂ S 3ppm 70 TO 80% R H. FOR 96 h				
RESISTANCE TO SOLDERING HEAT (REFLOW)	REFLOW TWICE UNDER THERECOMMENDED REFLOW TEMPERATURE PROFILE IN FIG-1	NO SIGNIFICANT DEFOMATION OR LOSSENESS OF CONTACTS.	X	—	
RESISTANCE TO SOLDERING, SOLDER IRON METHOD	TEMPERATURE OF SOLDERING IRON : 390°C MAX, 3 sec MAX	NO DAMAGE, CRACK AND LOOSENESS, OF PARTS.	X	—	
RECOMMENDED REFLOW PROFILE IN FIG-1					
	COUNT	DESCRIPTION OF REVISIONS	DESIGNED	CHECKED	DATE
△					
REMARK			APPROVED	NF. MIYAZAKI	10.03.25
			CHECKED	TA. ASO	10.03.25
			DESIGNED	KO. KAWAMURA	10.03.25
Unless otherwise specified, refer to JIS C 5402.			DRAWN	KO. KAWAMURA	10.03.25
Note QT:Qualification Test AT:Assurance Test X:Applicable Test			DRAWING NO.		ELC4-127058-00
HRS	SPECIFICATION SHEET		PART NO.	3860-B-18S	
	HIROSE ELECTRIC CO., LTD.		CODE NO.	CL238-2006-7-00	△ 1/2

ATTACHMENT FIGURE

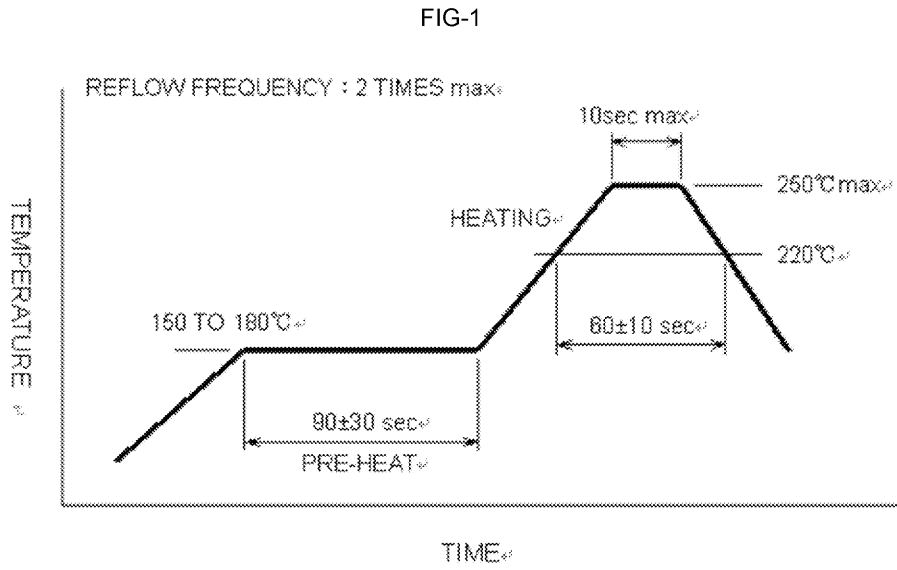

Note QT:Qualification Test AT:Assurance Test X:Applicable Test

DRAWING NO.

ELC4-127058-00



SPECIFICATION SHEET

PART NO.

3860-B-18S

HIROSE ELECTRIC CO., LTD.

CODE NO

CL238-2006-7-00



2/2

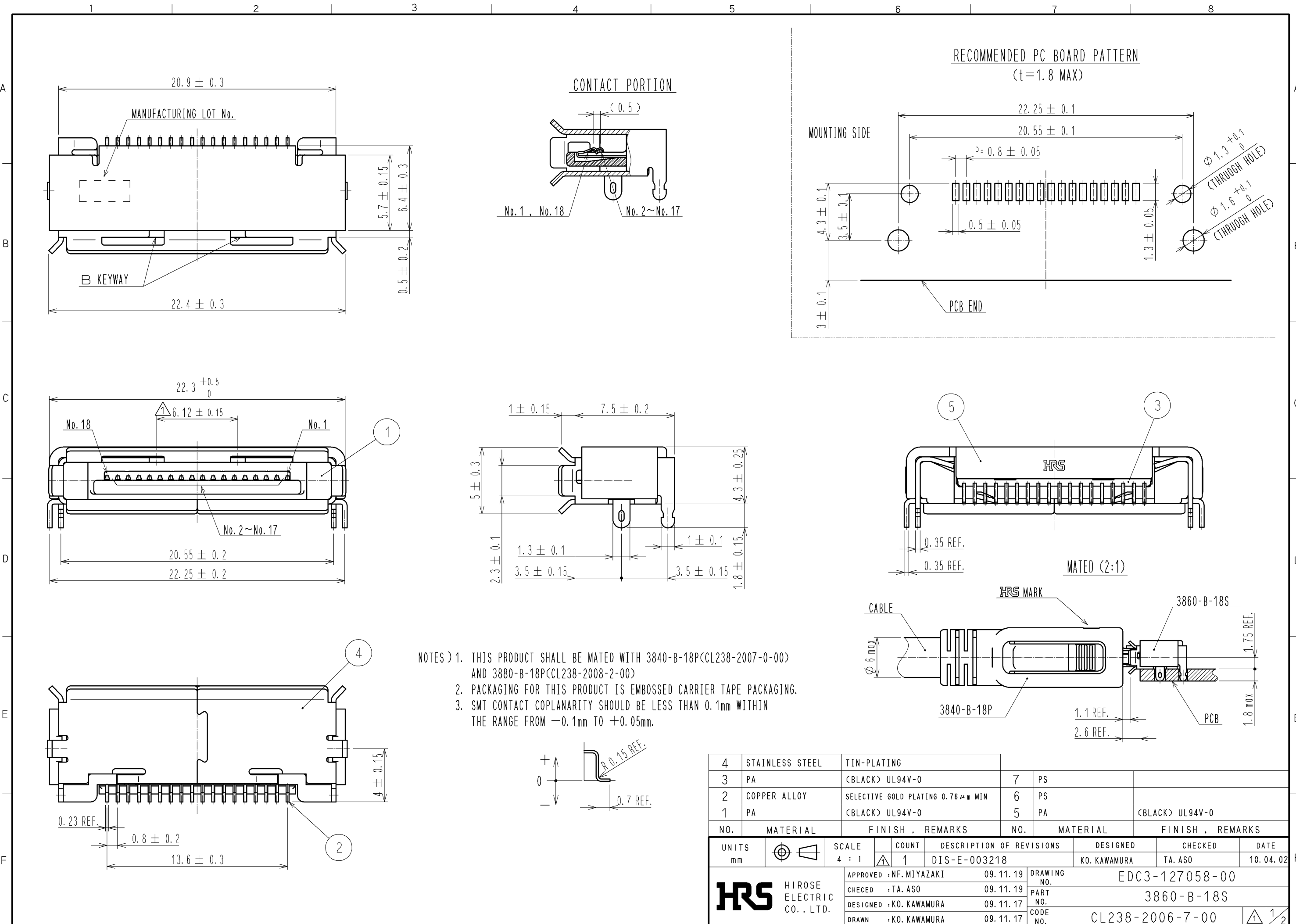

- NOTES) 1. THIS PRODUCT SHALL BE MATED WITH 3840-B-18P(CL238-2007-0-00) AND 3880-B-18P(CL238-2008-2-00)
 2. PACKAGING FOR THIS PRODUCT IS EMBOSSED CARRIER TAPE PACKAGING.
 3. SMT CONTACT COPLANARITY SHOULD BE LESS THAN 0.1mm WITHIN THE RANGE FROM -0.1mm TO +0.05mm.

4	STAINLESS STEEL	TIN-PLATING					
3	PA	(BLACK) UL94V-0	7	PS			
2	COPPER ALLOY	SELECTIVE GOLD PLATING 0.76 μm MIN	6	PS			
1	PA	(BLACK) UL94V-0	5	PA	(BLACK) UL94V-0		
NO.	MATERIAL	FINISH . REMARKS	NO.	MATERIAL	FINISH . REMARKS		
UNITS	mm	SCALE	4 : 1	COUNT	1	DESCRIPTION OF REVISIONS	DESIGNED
						DIS-E-003218	KO. KAWAMURA
							CHECKED
							TA. ASO
							DATE
							10.04.02
APPROVED : NF. MIYAZAKI		09.11.19	DRAWING NO.		EDC3-127058-00		
CHECKED : TA. ASO		09.11.19	PART NO.		3860-B-18S		
DESIGNED : KO. KAWAMURA		09.11.17	CODE NO.		CL238-2006-7-00		
DRAWN : KO. KAWAMURA		09.11.17					

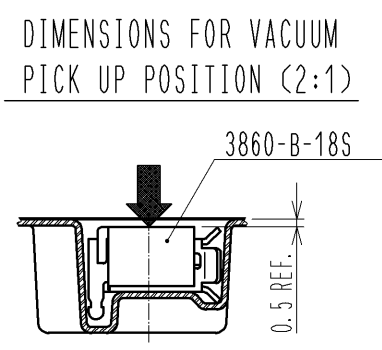
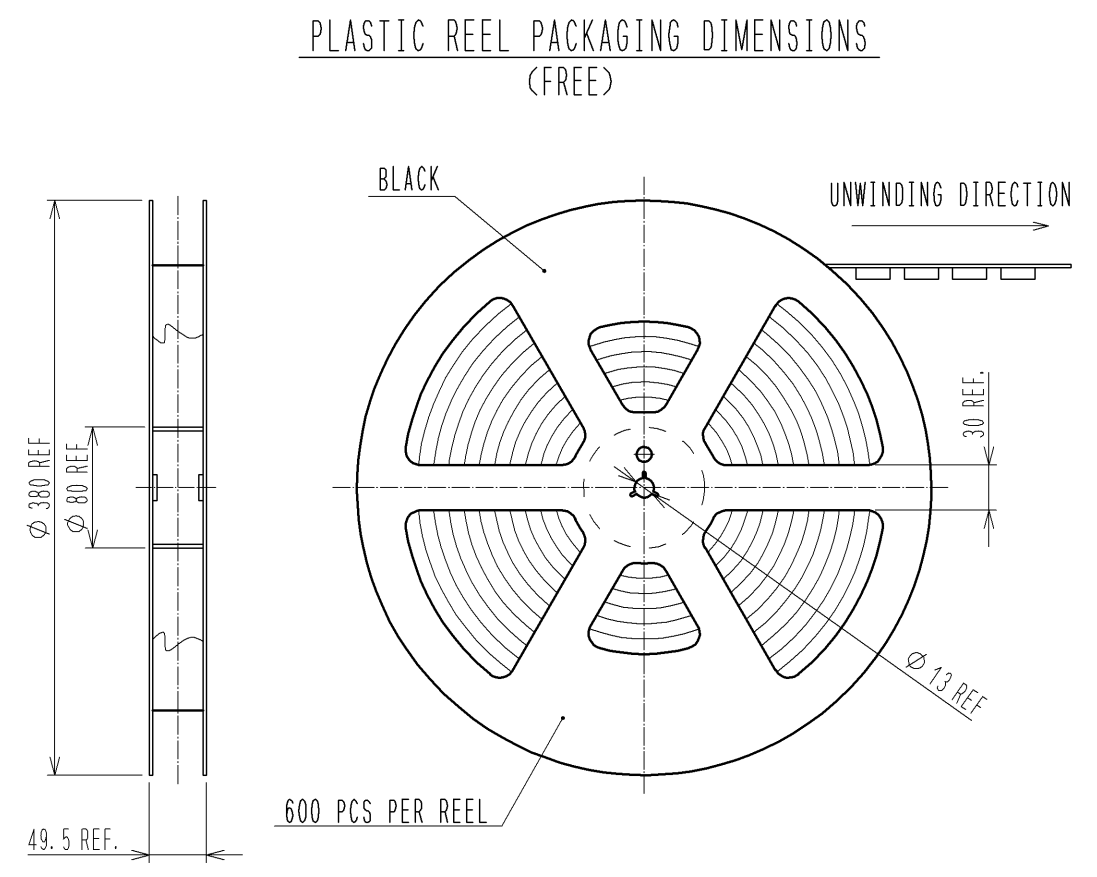
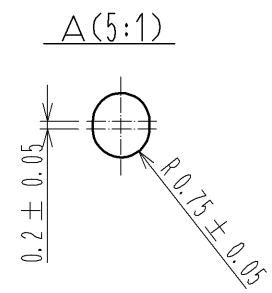
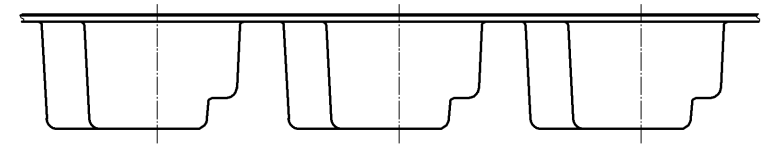
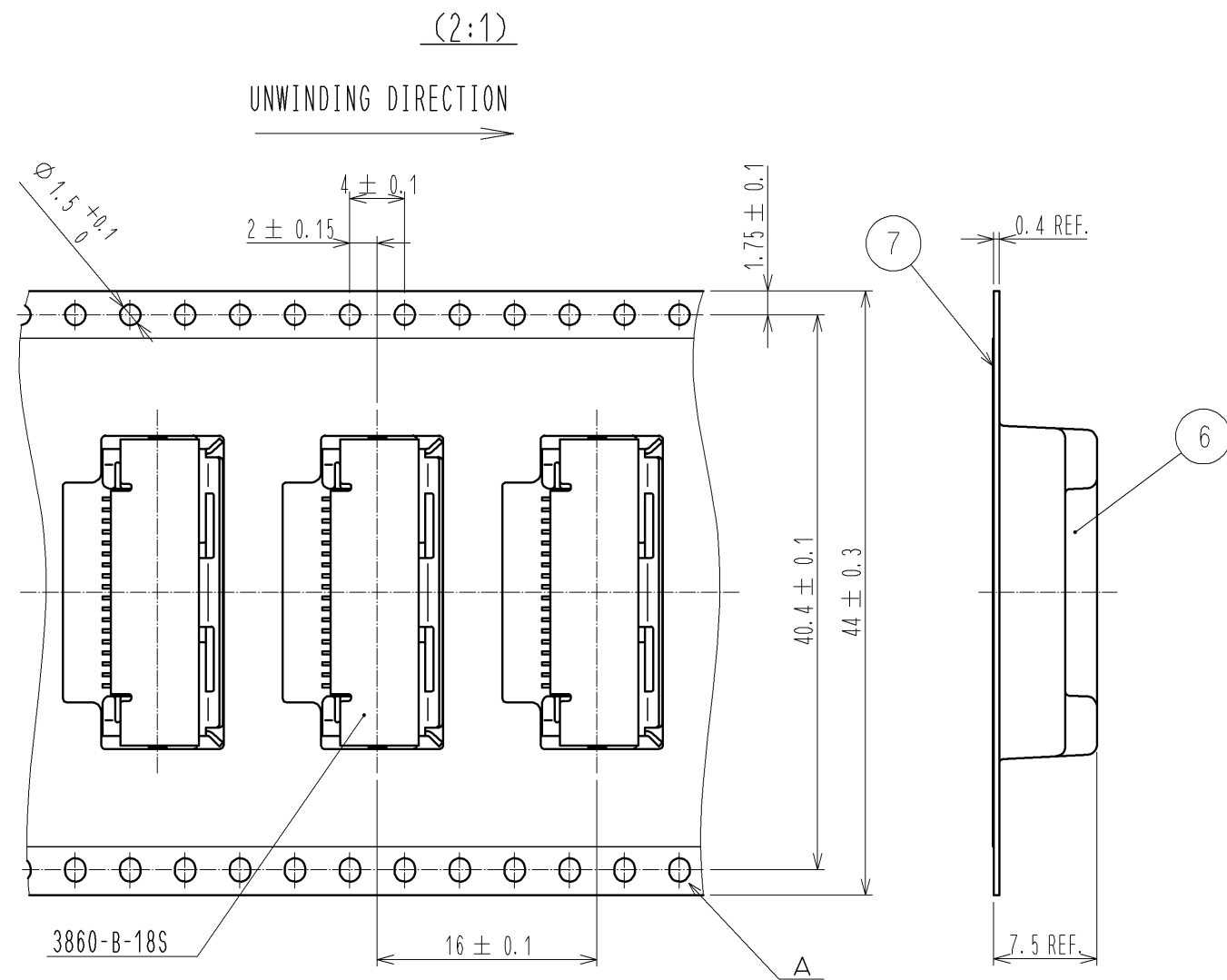

HRS	DRAWING NO.	EDC3-127058-00	
	PART NO.	3860-B-18S	
	CODE NO.	CL238-2006-7-00	